

**kW** Máx 16,5

**kW** 15,5-6,5

**kW** 1,5-1,5

**kW** 14-5

**m³** 387

**%** 93-96

**kg/h** 3,7-1,5

**h** 5,6-17,5

**W** 70-300 W

**kg** 21

**°C** 40/80

**8**

**bar** 1,5

**bar** max 2,4

**82**

**120**

**Ø 80 mm**

**50 mm**

**Interior metálico**  
Metalic inside

**Quemador en fundición**  
Cast-iron burner  
Queimador em fundição

**kg** 131

**S2**

**A** VAL-02, VAL-04, PE-130

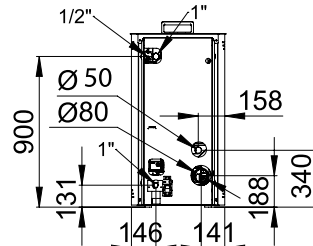
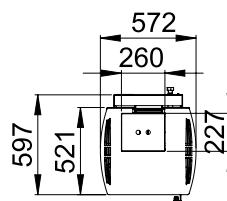
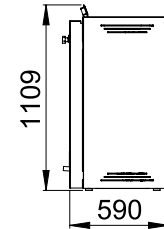
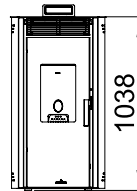
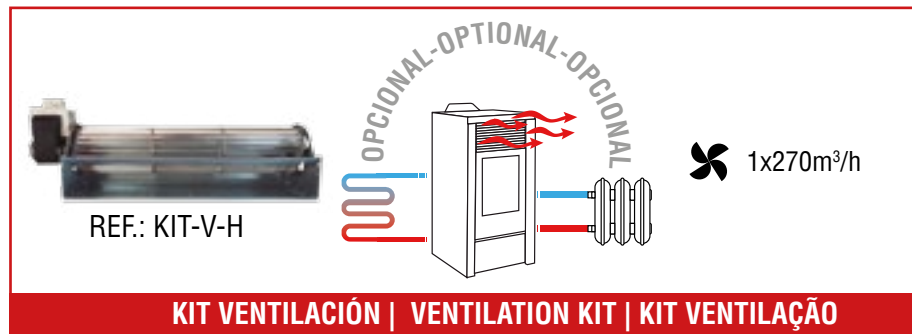

Mando a distancia incluido.  
Remote control included.  
Comando à distância incluído.



**NOA-H-MO**



**NOA-H-NE**

# Noa Hydro



NOA-H-MF



Controle su estufa desde cualquier lugar.  
Control your stove from anywhere.  
Controle a sua salamandra apartir de qualquer lugar.  
REF.: KIT WIFI 1





# Clara Hydro

Termoestufa de pellet  
Pellet back boiler  
Termosalamandra a pellet



Controle su estufa desde cualquier lugar.  
Control your stove from anywhere.  
Controle a sua salamandra apartir de qualquer lugar.  
REF.: KIT WIFI 1



CLARA-H





**kW** 15  
Máx

**kW** 14-6,8

**kW** 2,3-1

**kW** 11,8-5,8

**m³** 350

**%** 94-97

**kg/h** 3,2-1,5

**h** 8-16,6

**W** 150-400 W

**kg** 25

**°C** 40/80

**l** 6

**bar** 1,5

**bar** 2,5  
max

**mm** 85

**mm** 118



**mm** 80

**mm** 40

**Interior metálico**  
Metalic inside

**Quemador en fundición**  
Cast-iron burner  
Queimador em fundição

**kg** 169

**S2**

**A** VAL-02,VAL-04,  
PE-130

Posibilidad de salida de humos superior, lateral o trasera.  
Possibility of upper, rear or side smoke outlet.  
Possibilidade de saída de fumos superior, lateral ou traseira.

Gestión de calefacción y ACS.  
Management of heating and sanitary hot water.  
Gestão do Aquecimento Central e das AQS.

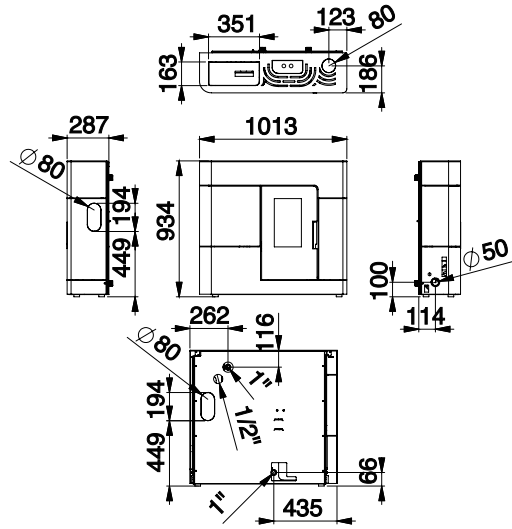

Mando a distancia incluido.  
Remote control included.  
Comando à distância incluído.



Con fácil acceso a mantenimientos.  
With easy access to maintenance.  
Com fácil acesso a manutenção.



**CLARA-H**



# Carlota-Ne

Termoestufa de pellet  
Pellet back boiler  
Termosalamandra a pellet



Limpieza totalmente automatizada de intercambiadores y quemador.  
Fully automatic cleaning of exchangers and burner.  
Limpeza totalmente automática dos permutadotes e do queimador.



**kW**  
Máx 23

**kW** 20,2-7,2

**kW**<sub>h</sub> 18-6,8

**m<sup>3</sup>** 505

**%** 91-96

4,9-1,5

9,8-32 h

48 kg

129

180

**W** 150-500

80 mm

60 mm

Interior metálico  
Metalic inside

Quemador en fundición  
Cast-iron burner  
Queimador em fundição

**kg** 198

40/80

8

**bar** 1,5

**bar**  
max 2,5

**S2**

**A** VAL-02, VAL-04,  
PE-130

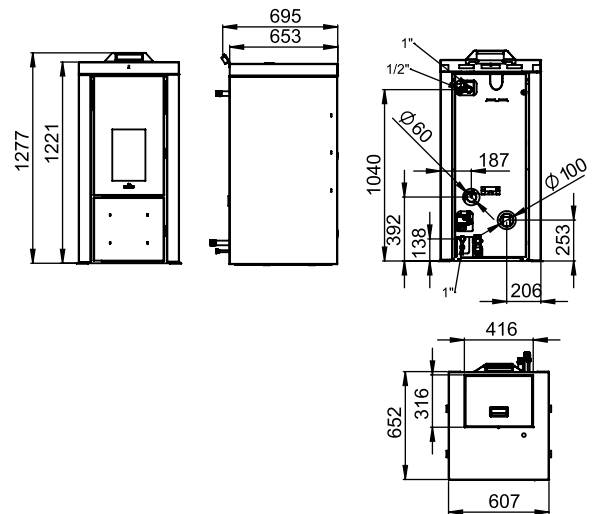

Gestión de calefacción y ACS.  
Conjunto del soporte y rascadores en acero inox.  
Purgador automático.  
Transductor de presión.  
Cámara aislada térmicamente.

Heating and domestic hot water management.  
Stainless steel support and scrapers.  
Automatic air vent.  
Pressure setting valve.  
Thermally insulated chamber.

Gestão do aquecimento central e das AQS.  
Conjunto do suporte e rascadores em aço inoxidável.  
Purgador automático.  
Transdutor de pressão.  
Câmara isolada térmicamente.



Mando a distancia incluido.  
Remote control included.  
Comando à distância incluído.



**CARLOTA-NE**